



AQUATEC[®]
E V O L U T I O N



**Materiali
abrasivi**



Ca orice companie de succes si *Aquatec Evolution* este alcatuit in primul rand din *oameni*. Personalul nostru, de peste 100 de angajati la *nivel national*, asigura functionalitatea retelei de distributie care acopera toata *Romania*. Echipa a fost creata in timp prin selectiune atenta si este formata astazi din oameni dinamici, cu o *experienta* considerabila in domeniul finisajelor profesionale. Acordam o importanta majora formarii si perfectionarii noastre profesionale, participand regulat la cursuri de pregatire si seminarii de profil. Fiecare angajat inainte de a incepe activitatea in cadrul firmei sau de a intra in contact cu clientii trece printr-un program intens de pregatire profesionala specifica postului.

Activitatea noastra se bazeaza pe o structura de departamente specifice interconectate intre ele printr-o stransa colaborare. Astfel incat atat fluxul informational, cat si procesele productive se desfasoara in mod fluid asigurand raspunsuri prompte si solutii pe masura fiecarii situatii. Dedicarea, atitudinea profesionala si *atentia fata de client*, sunt calitatile pe care noi le promovam la nivelul intregului colectiv. Incercam de fiecare data sa fim un *partener* de incredere, cu cunostinte, abilitati si dotare tehnica care ne ajuta sa raspundem rapid si competent oricarei solicitari din partea clientilor nostrii.

Activitatea de baza a firmei o reprezinta *distributia* produselor profesionale de finisare pentru industria lemnului, metalului, sticlei, constructiilor, etc, dar si produse complementare, precum: materiale abrazive, chituri, echipamente de pulverizare. Conceptul in sine pleaca de la ideea de a dezvolta o gama completa de produse si servicii cu scopul de a oferi pietii, solutii moderne de finasare a suprafetelor, atat in amenajarea spatiilor private si profesionale, cit si celor publice sau de agrement. In aceasta misiune ne bazam atat pe infrastructura si experienta proprie, cat si pe sprijinul furnizorilor nostri. De-a lungul anilor am reusit sa aducem aproape de noi nume cunoscute pe plan international din industria vopselilor pentru lemn, vopselilor industriale si celor pentru constructii. Impreuna cu partenerii nostrii am reusit sa creem cea mai mare retea de distributie specializata in produse profesionale de vopsit din tara.

Structura si distributia *filialelor* au fost concepute in ideea de a acoperi toata harta si de a avea un consultant si un punct de desfacere cat mai aproape de fiecare client. *Reteaua* noastra este structurata capilar astfel incat, pe langa sediile principale *din Bucuresti, Cluj Napoca si Arad*, detine si filiale amplasate strategic in toate regiunile tarii. In toate punctele de lucru, in functie de nivelul de autonomie fata de sediul principal, exista atat personal comercial cat si tehnic capabil sa asigure serviciile catre clienti la cel mai ridicat nivel in conformitate cu standardele companiei noastre. Astfel detinem in mod direct in *Romania* mii de metri patrati de spatii comerciale, tehnice si de depozitare pe care le deservim cu un impresionant parc de mijloace auto si echipamente.

Compania a luat nastere la inceputul anului *2006* in *Bucuresti* sub nume de *LomiluxB*. Afacerea a pornit de la zero cu foarte putine resurse materiale, dar cu foarte multa ambitie de a reusi. Fondatorii companiei aveau la baza o experienta in domeniul vopselilor pentru lemn si au pornit la drum cu ideea de a dezvolta o afacere proprie in acest domeniu foarte particular. Cu foarte multa inspiratie dar si cu un efort considerabil compania a inceput sa inregistreze progrese rapide pe piata din Romania. Astfel incat dupa numai cativa ani am devenit un nume cunoscut si un partener de baza pentru multe companii producatoare din tara. Acest rezultat ne-a permis sa incepem expansiunea teritoriala astfel incat tot in acea perioada au inceput sa infiintam si primele filiare in teritoriu, *Iasi si Valcea*. Din anul *2010* am inceput un amplu program de *investitii in infrastructura* pe care l-am sustinut din rezultatele, din ce in ce mai bune, din activitate. Acesta viza pe de o parte construirea si amenajarea facilitatilor necesare desfasurarii activitatii de baza, cat si constituirea unui colectiv de specialisti competenti. In toata aceasta perioada am avut sansa sa alaturam achipei noastre persoane foarte valoroase, profesionisti, care au contribuit cu multa dedicatie la efortul comun care a dus realizarile cu care ne mandrim. Acest proces de investire si evolutie continue si in prezent prin propunerea unor noi obiective din ce in ce mai ambitioase.





Abrazivii - sunt materiale dure lipite pe un suport, cu ajutorul carora prin frecare (slefuire), se pot desprinde aschii mici dintr-un material, cu scopul de a netezi, indrepta, remedia prelucrarile anterioare si de a crea o suprafata aderenta straturilor ulterioare. De-a lungul timpului aceste materiale au cunoscut o evolutie, atat ca denumire, trecand de la *glaspapir*, *smirgel*, la cea ce azi numim simplu *abrazive*, cat si ca materii prime, papirul, cojile zdrobite, semintele, sticla zdrobita, pielea pestilor fiind inlocuite cu materiale moderne, atat pentru suport, folosindu-se *panza*, *hartie latexata*, *fibre*, *film poliestic*, cat si pentru material abraziv, utilizandu-se minerale precum: *oxid de aluminiu*, *carbura de siliciu*, *oxid de zirconiu*, *ceramic*. Dispunerea mineralului pe suport poate fi: *inchisa*, *deschisa*, *semi-deschisa*.

In alegerea abrazivului trebuie sa tinem cont de: suport - granulatie P - dispunerea mineralului. Marimea mineralelor determina *GRANULATIA (P)*, si nu trebuie tratata cu superficialitate, ci trebuie adaptata in functie de materialul pe care-l finisam si de ce urmeaza sa aplicam peste. Spre exemplu un abraziv cu granulatia de P80 este mai agresiv decat un abraziv cu granulatia P180; ultima granulatie pe care o folosim pentru a slefui un lemn de esenta tare, ex. stejar, inainte de aplicarea statului de bait si/sau grund, este recomandat sa fie P150; in schimb un lemn de esenta moale sau furniruri, ultima granulatie este P180.

In concluzie, indiferent de ce material/suport dorim sa finisam, metal, lemn, mdf, perete etc, nu putem obtine un rezultat de calitate daca nu slefuim. In functie de etapa de prelucrare in care efectuam slefuirea, abrazivele se clasifica astfel: *pentru slefuirea in brut*, granulatii <P180 - *pentru slefuirea intre straturi*, granulatii P240 - P800 - *pentru polish-are*, granulatii P1000 - P5000

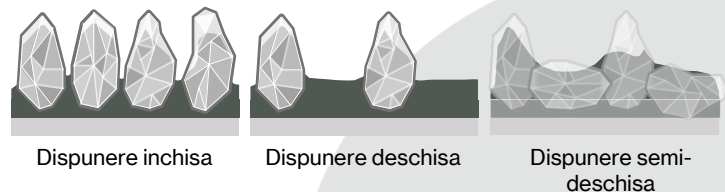
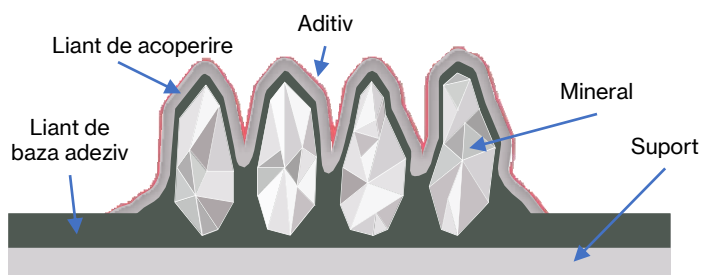

Role panza abraziva



DA-F – panza abraziva flexibila F + dubla rasina, cu oxid de aluminiu dispus deschis si aditivi activi pentru reducerea colmatarii abrazivului. Recomandata pentru slefuirea manuala in brut a lemnului masiv, furnirului, MDF, metalului inainte de vopsire.

Cod Mentor	Cod Produs	mm x ml			Producator	+ TVA
AB DAF P80 100x50	DA-F	100 x 50	P80	stoc	SAIT	44.80
AB DAF P120 100x50	DA-F	100 x 50	P120	stoc	SAIT	44.80
AB DAF P150 100x50	DA-F	100 x 50	P150	stoc	SAIT	44.80
AB DAF P180 100x50	DA-F	100 x 50	P180	stoc	SAIT	44.80

P60; P100; P220; P240; P320; P400 – se pot aduce pe comanda in aprox. 3-4 saptamani



SAINT-GOBAIN

R222 – panza abraziva flexibila J + dubla rasina, cu oxid de aluminiu dispus semi-deschis si aditivi activi ce reduc colmatarea (incarcarea) abrazivului. Recomandata pentru slefuirea in brut a lemnului masiv, furnirului, MDF, metalului inainte de vopsire.



Cod Mentor	Cod Produs	mm x ml			Producator	+ TVA
AB R222 P80	R222	115 x 50	P80	stoc	Norton	72.93
AB R222 P100	R222	115 x 50	P100	stoc	Norton	71.84
AB R222 P120	R222	115 x 50	P120	stoc	Norton	71.84
AB R222 P150	R222	115 x 50	P150	stoc	Norton	71.84
AB R222 P180	R222	115 x 50	P180	stoc	Norton	71.84
AB R222 P240	R222	115 x 50	P240	stoc	Norton	71.80





6A – hartie latexata abraziva flexibila B + dubla rasina, cu *oxid de aluminiu* dispus *deschis* si aditivi activi pentru reducerea colmatarii (incarcarii) abrazivului. Recomandata pentru slefuirea uscata intre straturi in industria lemnului si auto, a grundurilor, chiturilor, vopselelor si lacurilor.



Cod Mentor	Cod Produs	mm x ml			Producator	+ TVA
AB 6A P240 115x50	6A	115 x 50	P240	stoc	Sait	28.48
AB 6A P320 115x50	6A	115 x 50	P320	stoc	Sait	28.48
AB 6A P400 115x50	6A	115 x 50	P400	stoc	Sait	28.48
AB 6A P240 115x100	6A	115 x 100	P240	stoc	Sait	57.86
AB 6A P320 115x100	6A	115 x 100	P320	stoc	Sait	57.86
AB 6A P400 115x100	6A	115 x 100	P400	stoc	Sait	57.86

P120; P150; P180; P220; P280; P600 – se pot aduce pe comanda in aprox. 3-4 saptamani



SAINT-GOBAIN

A275 – hartie latexata abraziva flexibila A + dubla rasina, cu *oxid de aluminiu* dispus *deschis* si aditivi activi pentru reducerea colmatarii abrazivului. Recomandata pentru slefuirea uscata intre straturi in industria lemnului, a grundurilor, chiturilor, vopselelor si lacurilor.



Cod Mentor	Cod Produs	mm x ml			Producator	+ TVA
AB A275 P240	A275	115 x 50	P240	stoc	Norton	38.69
AB A275 P280	A275	115 x 50	P280	stoc	Norton	38.69
AB A275 P320	A275	115 x 50	P320	stoc	Norton	38.69
AB A275 P360	A275	115 x 50	P360	stoc	Norton	55.15
AB A275 P400	A275	115 x 50	P400	stoc	Norton	38.69
AB A275 P600	A275	115 x 50	P600	stoc	Norton	48.64





6A – hartie latexata buretata abraziva flexibila B + dubla rasina, cu oxid de aluminiu dispus *deschis* si aditivi activi pentru reducerea colmatarii abrazivului. Recomandata pentru slefuirea uscata intre straturi in industria lemnului si auto a grundurilor, chiturilor, vopselelor si lacurilor.

Cod Mentor	Cod Produs	 mm x ml			Producator	 +TVA
AB 6A P150 RF 115x25	6A	115 x 25	P150	stoc	Sait	29.80
AB 6A P180 RF 115x25	6A	115 x 25	P180	stoc	Sait	29.80
AB 6A P240 RF 115x25	6A	115 x 25	P240	stoc	Sait	29.80
AB 6A P320 RF 115x25	6A	115 x 25	P320	stoc	Sait	29.80
AB 6A P400 RF 115x25	6A	115 x 25	P400	stoc	Sait	29.80



P120; P150; P220; P280; P600 – se pot aduce pe comanda in aprox. 3-4 saptamani



SAINT-GOBAIN



A275 – hartie buretata latexata abraziva flexibila A + dubla rasina, cu oxid de aluminiu dispus *deschis* si aditivi activi pentru reducerea colmatarii abrazivului. Recomandata pentru slefuirea uscata intre straturi in industria lemnului a grundurilor, chiturilor, vopselelor si lacurilor.

Cod Mentor	Cod Produs	 mm x ml			Producator	 +TVA
AB A275 P180 RF	A275	115 x 25	P180	Stoc	Norton	51.12
AB A275 P240 RF	A275	115 x 25	P240	Stoc	Norton	51.12
AB A275 P280 RF	A275	115 x 25	P280	Stoc	Norton	51.12
AB A275 P320 RF	A275	115 x 25	P320	stoc	Norton	51.12
AB A275 P360 RF	A275	115 x 25	P360	stoc	Norton	51.12
AB A275 P400 RF	A275	115 x 25	P400	stoc	Norton	51.12

Coli hartie abraziva cu oxid de aluminiu si/sau carbura de siliciu. Utilizare uscata sau la ud.



Cod Mentor	Cod Produs	 mm			Producator	 +TVA
LBA RSASN 230x280 P240	RSAS	230 x 280	P240	Stoc	LBA	0.4
LBA RSASN 230x280 P320	RSAS	230 x 280	P320	Stoc	LBA	0.4
LBA RSASN 230x280 P400	RSAS	230 x 280	P400	Stoc	LBA	0.4
AB CWC 230x280 P600	CWC	230 x 280	P600	Stoc	Sait	0.4
LBA NC07 230x280 P1000	NC07	230 x 280	P1000	Stoc	LBA	0.4
LBA NC07 230x280 P1500	NC07	230 x 280	P1500	Stoc	LBA	0.4
LBA NC07 230x280 P2000	NC07	230 x 280	P2000	Stoc	LBA	0.4



AW-D – hartie latexata abraziva, *D + dubla rasina*, cu oxid de aluminiu dispus deschis si aditivi activi pentru reducerea colmatarii abrazivului. Recomandata pentru slefuirea uscata cu roto-orbitale in industria lemnului, auto si nautica a lemnului masiv, MDF, grundurilor, chiturilor si a materialelor din otel si otel inoxidabil



Cod Mentor	Cod Produs	mm			Producator	€ +TVA *
AB AWD Ø150 P80	AW-D	Ø150 15H	P80	stoc	Sait	15.20
AB AWD Ø150 P120	AW-D	Ø150 15H	P120	stoc	Sait	15.20
AB AWD Ø150 P150	AW-D	Ø150 15H	P150	stoc	Sait	15.20

*-Pretul este pentru cutie de 50 discuri.

P40; P60; P100 – se pot aduce pe comanda in aprox. 3-4 saptamani

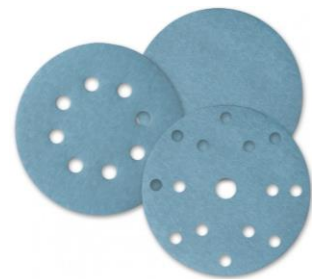

5S – hartie abraziva flexibila, C + dubla rasina, cu mineral **ceramic** dispus “deschis” si aditivi activi pentru reducerea colmatarii abrazivului. Recomandata pentru slefuirea uscata cu roto-orbitale, intre straturi in industria lemnului, auto si nautica a grundurilor, chiturilor, vopselelor si lacurilor si a materialelor din otel si otel inoxidabil

Cod Mentor	Cod Produs	mm			Producator	€ +TVA *
AB 6S Ø150 P240	6S	Ø150 15H	P240	stoc	Sait	35.20
AB 6S Ø150 P320	6S	Ø150 15H	P320	stoc	Sait	35.20
AB 6S Ø150 P400	6S	Ø150 15H	P400	stoc	Sait	35.20
AB 6S Ø150 P600	6S	Ø150 15H	P600	stoc	Sait	35.20

*-Pretul este pentru cutie de 100 discuri.

P60; P80; P100; P120; P150; P180; P220; P280; P500; P800; P1200 – se pot aduce pe comanda in aprox. 3-4 saptamani





5G – hartie latexata abraziva B + dubla rasina, cu oxid de aluminiu dispus “deschis” si aditivi activi pentru reducerea colmatarii abrazivului. Recomandata pentru slefuirea uscata cu roto-orbitale in industria lemnului, auto a grundurilor, chiturilor, vopselelor si lacurilor.

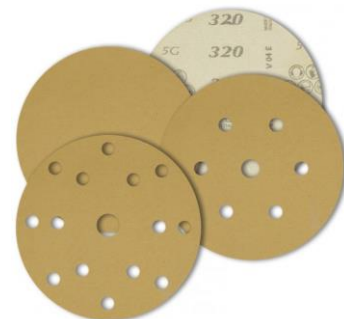

Cod Mentor	Cod Produs	 mm			Producator	 +TVA *
AB 5G Ø150 P180	5G	Ø150 15H	P180	stoc	Sait	26.00
AB 5G Ø150 P240	5G	Ø150 15H	P240	stoc	Sait	26.00
AB 5G Ø150 P320	5G	Ø150 15H	P320	stoc	Sait	26.00
AB 5G Ø150 P400	5G	Ø150 15H	P400	stoc	Sait	26.00
AB 5G Ø150 P500	5G	Ø150 15H	P500	stoc	Sait	26.00

*-Pretul este pentru cutie de 100 discuri.

P40; P60; P80; P100; P120; P150; P220; P280; P360; P600; P800 – se pot aduce pe comanda in aprox. 3-4 saptamani

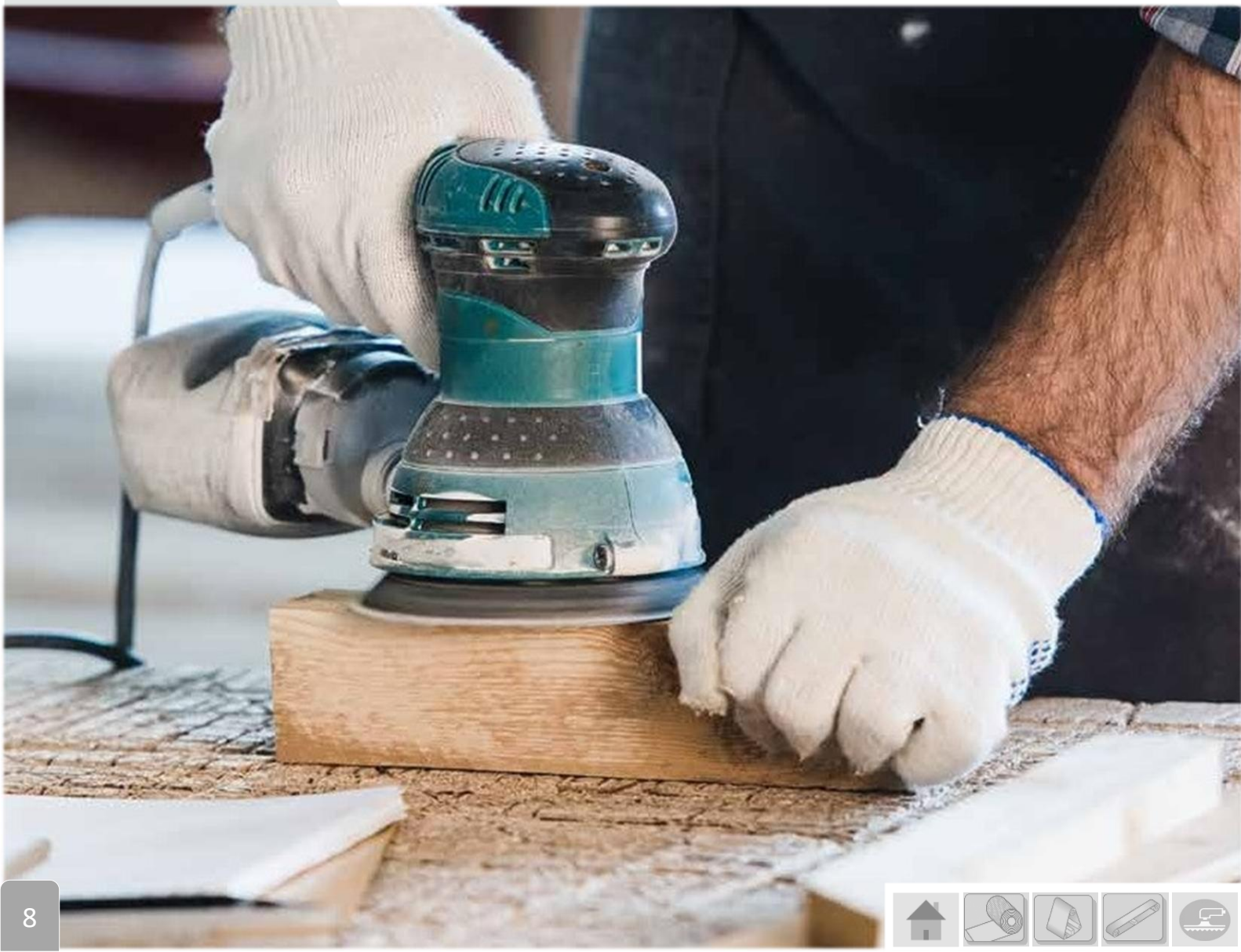

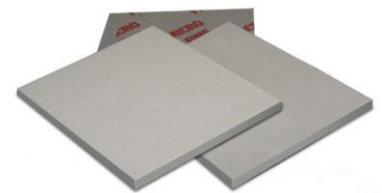

Sponge – abraziv pe burete sintetic, moale, de inalta densitate. Recomandat pentru slefuirea uda si/sau uscata a profilelor, marginilor si pieselor profilate.

Cod Mentor	Cod Produs	mm			Producator	+TVA
AB SPONGE SF	SFA	115 x 140 x 5	220	stoc	Sait	0.79
AB SPONGE UF	UFA	115 x 140 x 5	400	stoc	Sait	0.79
AB SPONGE MF	MFA	115 x 140 x 5	600	stoc	Sait	0.79

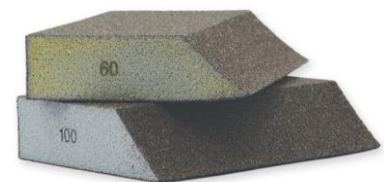

Sponge 4F ASCUTIT– abraziv pe burete sintetic. Recomandat pentru slefuirea uscata si sau uda la 90° a profilelor, marginilor si pieselor profilate.

Cod Mentor	Cod Produs	mm			Producator	+TVA
AB SPONGE BLOCK 4 F100A	4F FA	100 x 68.5 x 27	100	stoc	Sait	0.79
AB SPONGE BLOCK 4 SF150A	4F SFA	100 x 68.5 x 27	150	3 – 4 saptamani	Sait	0.79
AB SPONGE BLOCK 4 VF180A	4F VFA	100 x 68.5 x 27	180	stoc	Sait	0.79

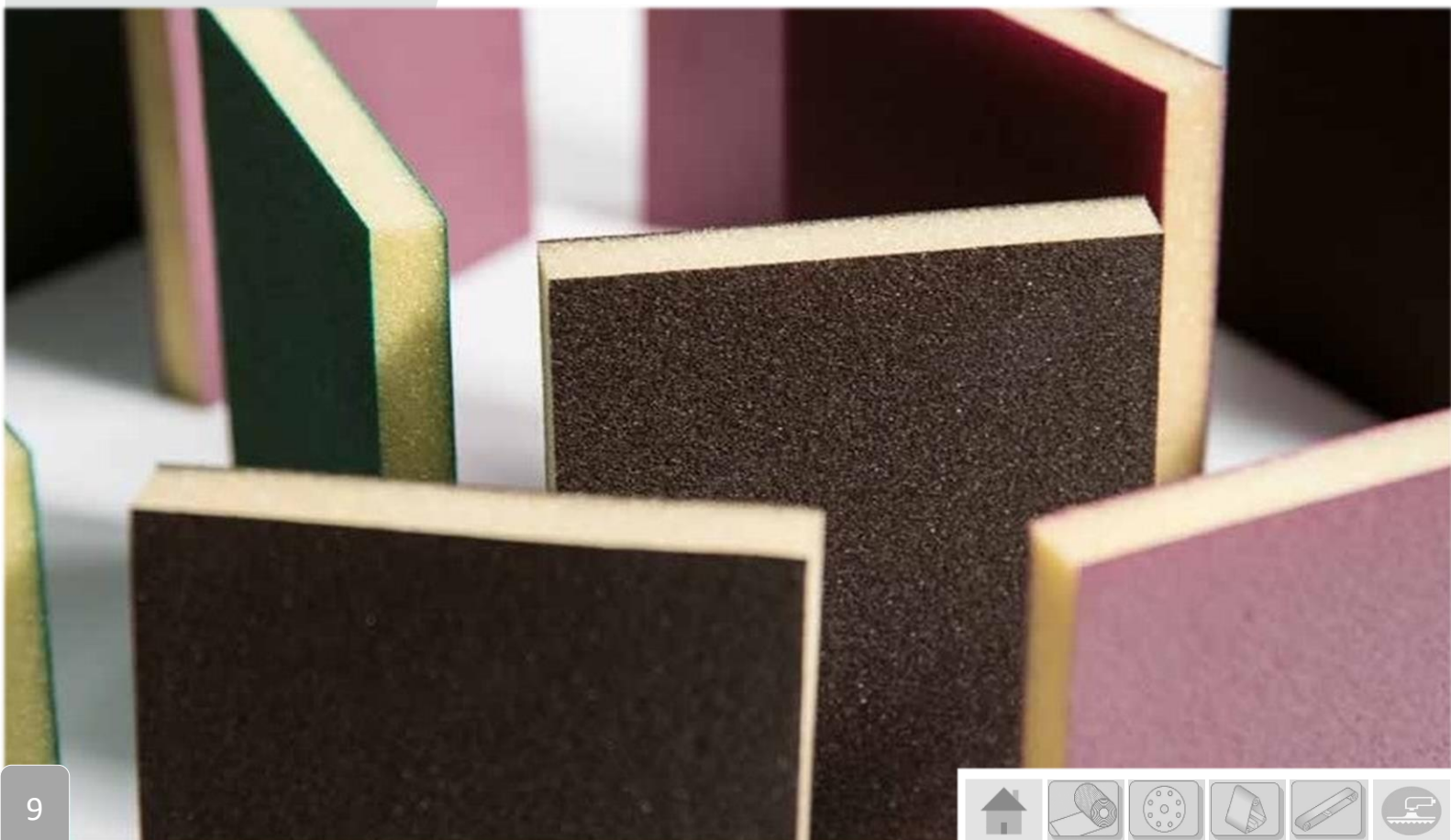



SAINT-GOBAIN



Sponge 4F – abraziv pe burete sintetice. Recomandat pentru slefuirea uscata la 90° a profilelor, marginilor si pieselor profilate.

Cod Mentor	Cod Produs	mm			Producator	+TVA
AB SPONGE 4 STR P100	4F	100 x 68.5 x 27	100	stoc	Norton	0.79
AB SPONGE 4 STR P150	4F	100 x 68.5 x 27	150	stoc	Norton	0.79
AB SPONGE 4 STR P180	4F	100 x 68.5 x 27	180	stoc	Norton	0.79

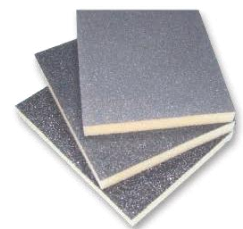

Sponge 2F – abraziv pe burete sintetice, moale, de inalta densitate. Recomandat pentru slefuirea uda si/sau uscata a profilelor, marginilor si pieselor profilate.

Cod Mentor	Cod Produs	mm			Producator	+TVA
AB SPONGE 2 STR P100	2F	123 x 98 x 12.5	100	stoc	Norton	0.55
AB SPONGE 2 STR P120	2F	123 x 98 x 12.5	120	stoc	Norton	0.55
AB SPONGE 2 STR P180	2F	123 x 98 x 12.5	180	stoc	Norton	0.55





Scotch Brite – fibra de netesut cu granule din oxid de aluminiu. Recomandat pentru slefuirea manuala a suprafetelor din lemn, metal plastic, vopsele.

Cod Mentor	Cod Proodus	mm			Producator	+TVA
AB TNT UF SCOTCH BRITE	TNT UF	120 x 280	Ultra Fin	stoc	Sait	1.10
AB TNT VF SCOTCH BRITE	TNT VF	120 x 280	Foarte Fin	stoc	Sait	1.10
AB TNT Ø150 FA	TNT FA	150 x 10 x 10	Fin	stoc	Sait	0.98



Lana otel – Destinata pentru curatarea diferitelor suprafete si pentru evidentierea fibrei lemnului. Este lavabila si reutilizabila. Recomandat pentru slefuirea manuala a suprafetelor din lemn, metal plastic, vopsele.

Cod Mentor	Cod Proodus	mm			Producator	+TVA
DC LANANAZ	lana	----	Grosiera	stoc	Sprint Chimica	6.16 kg
DC LANANAZ UF	lana	----	Foarte Fina	stoc	Sprint chimica	7.22 kg



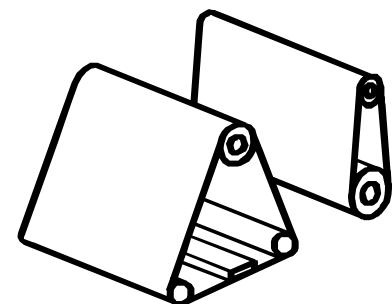



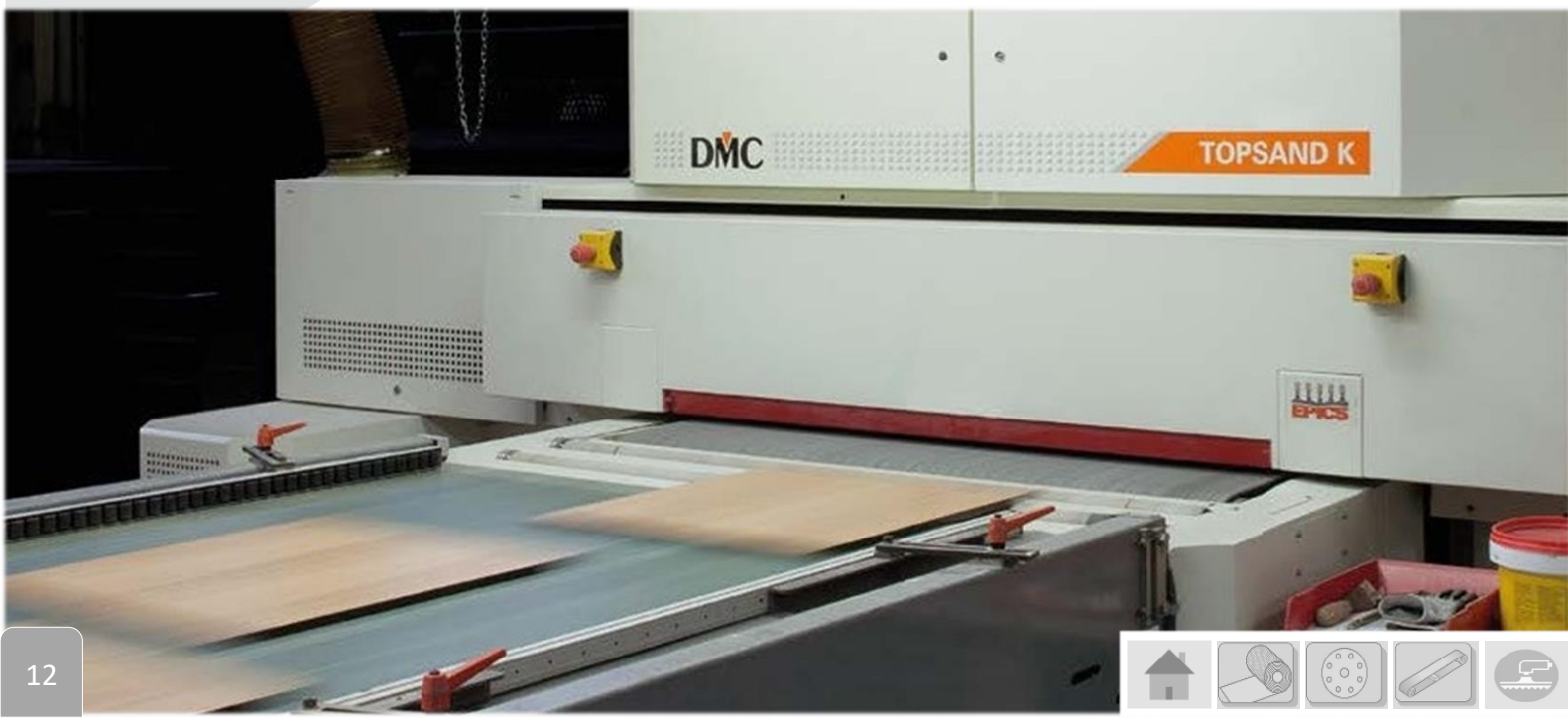

TXA – panza din poli-bumbac X cu oxid de aluminiu dispus deschis + aditivi activi anti-static. Recomandat pentru calibrarea/slefuirea elementelor din lemn masiv, furniruri. Alte dimensiuni si/sau granulatii se pot aduce pe comanda in cca 3 saptamani.

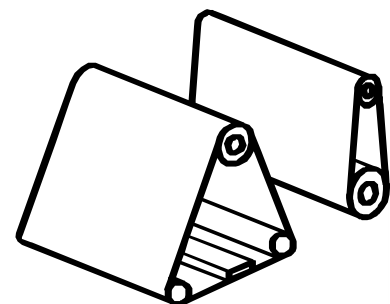
Cod Mentor	Cod Produs	mm 			Producator	
LBA TXA 1600x975 P80	TXA	1600 x 975	P80	stoc	LBA	29.06
LBA TXA 1600x975 P100	TXA	1600 x 975	P100	stoc	LBA	28.10
LBA TXA 1900x1120 P80	TXA	1900 x 1120	P80	stoc	LBA	34.37
LBA TXA 1900x1120 P120	TXA	1900 x 1120	P120	stoc	LBA	33.19
LBA TXA 1900x1300 P60	TXA	1900 x 1300	P60	stoc	LBA	41.16
LBA TXA 1900x1300 P80	TXA	1900 x 1300	P80	stoc	LBA	40.61
LBA TXA 1900x950 P60	TXA	1900 x 950	P60	stoc	LBA	28.40
LBA TXA 1900x950 P80	TXA	1900 x 950	P80	stoc	LBA	28.40
LBA TXA 2050x1115 P40	TXA	2050 x 1115	P40	stoc	LBA	38.34
LBA TXA 2050x1115 P60	TXA	2050 x 1115	P60	stoc	LBA	36.86
LBA TXA 2180x1135 P60	TXA	2180 x 1135	P60	stoc	LBA	38.62
LBA TXA 2200x1130 P40	TXA	2200 x 1130	P40	stoc	LBA	38.88
LBA TXA 2200x1130 P60	TXA	2200 x 1130	P60	stoc	LBA	38.88
LBA TXA 2620x1350 P40	TXA	2620 x 1350	P40	stoc	LBA	52.72
LBA TXA 2620x1350 P80	TXA	2620 x 1350	P80	stoc	LBA	52.72
LBA TXA 2620x1350 P120	TXA	2620 x 1350	P120	stoc	LBA	52.72
LBA TXA 2620x1350 P150	TXA	2620 x 1350	P150	stoc	LBA	52.72







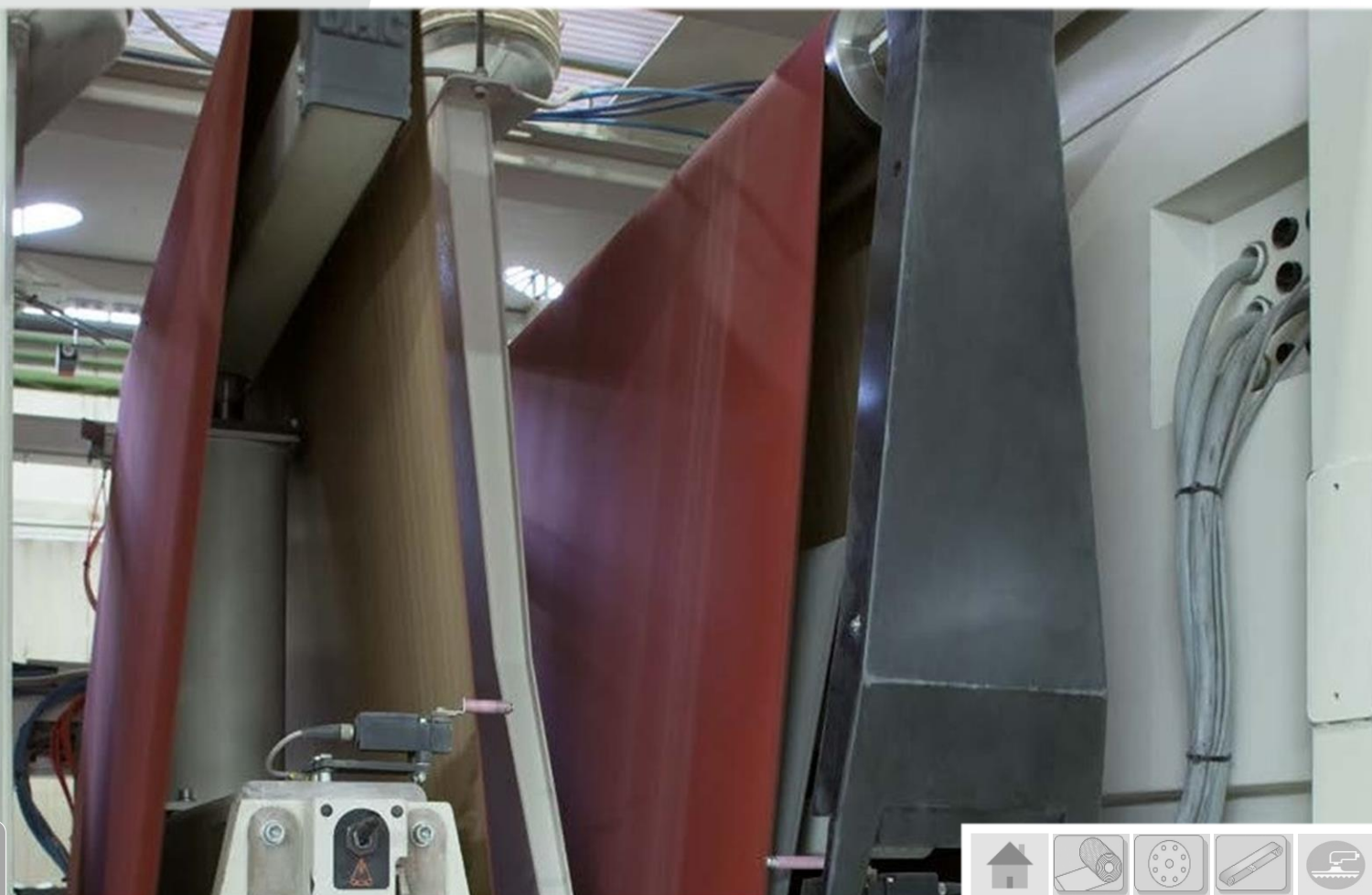

TLXGR – panza din poli-bumbac X cu oxid de aluminiu dispus semi-inchis + aditivi activi anti-static. Recomandat pentru calibrarea/slefuirea elementelor din lemn masiv, furniruri; metalelor neferoase, otel inoxidabil, aluminiu, alama etc.. Alte dimensiuni si/sau granulatii se pot aduce pe comanda in cca 3 saptamani.

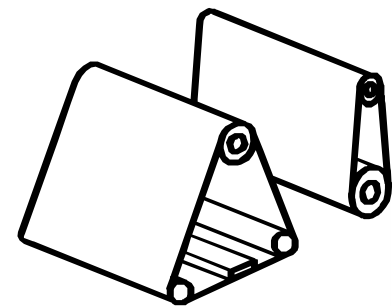
Cod Mentor	Cod Produs	 mm			Producator	 € +TVA
LBA TLXGR 1900x950 P150	TLXGR	1900 x 950	P150	stoc	LBA	32.38
LBA TLXGR 1900x950 P180	TLXGR	1900 x 950	P180	stoc	LBA	32.38
LBA TLXGR 1900x970 P60	TLXGR	1900 x 970	P60	stoc	LBA	45.02
LBA TLXGR 1900x970 P80	TLXGR	1900 x 970	P80	stoc	LBA	42.35
LBA TLXGR 1900x970 P100	TLXGR	1900 x 970	P100	stoc	LBA	39.20
LBA TLXGR 1900x970 P150	TLXGR	1900 x 970	P150	stoc	LBA	39.20
LBA TLXGR 1900x1120 P180	TLXGR	1900 x 1120	P180	stoc	LBA	39.20
LBA TLXGR 2210x1280 P40	TLXGR	2210 x 1280	P40	stoc	LBA	58.63
LBA TLXGR 2210x1280 P60	TLXGR	2210 x 1280	P60	stoc	LBA	58.63
LBA TLXGR 2210x1280 P100	TLXGR	2210 x 1280	P100	stoc	LBA	58.63
LBA TLXGR 2500x1150 P120	TLXGR	2500 x 1150	P120	stoc	LBA	48.70
LBA TLXGR 2620x1350 P180	TLXGR	2620 x 1380	P180	stoc	LBA	59.11







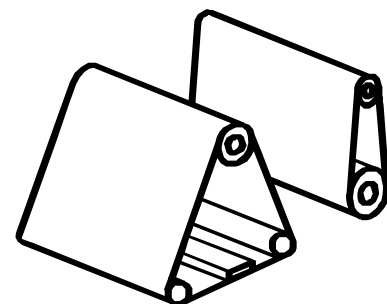

NF1102 – hartie F cu oxid de aluminiu dispus deschis. Recomandat pentru calibrarea/slefuirea elementelor din lemn masiv, furniruri, MDF, metale. Alte dimensiuni si/sau granulatii se pot aduce pe comanda in cca 3 saptamani.

Cod Mentor	Cod Produs	 mm			Producator	 € +TVA
LBA NF1102 1900x1120 P120	NF1102	1900 x 1120	P120	stoc	LBA	20.21
LBA NF1102 2200x1120 P120	NF1102	2200 x 1120	P120	stoc	LBA	23.51
LBA NF1102 2200x1120 P180	NF1102	2200 x 1120	P180	stoc	LBA	23.51
LBA NF1102 2210x1280 P40	NF1102	2210 x 1280	P40	stoc	LBA	27.87
LBA NF1102 2210x1280 P60	NF1102	2210 x 1280	P60	stoc	LBA	27.87
LBA NF1102 2210x1280 P80	NF1102	2210 x 1280	P80	stoc	LBA	27.87
LBA NF1102 2300x1130 P100	NF1102	2300 x 1130	P100	stoc	LBA	22.99
LBA NF1102 2300x1130 P120	NF1102	2300 x 1130	P120	stoc	LBA	22.99
LBA NF1102 2620x1350 P100	NF1102	2620 x 1350	P100	stoc	LBA	26.43
LBA NF1102 2620x1350 P120	NF1102	2620 x 1350	P120	stoc	LBA	26.43
LBA NF1102 2620x1350 P150	NF1102	2620 x 1350	P150	stoc	LBA	26.43
LBA NF1102 2620x1350 P180	NF1102	2620 x 1350	P180	stoc	LBA	26.43
LBA NF1102 2620x1350 P220	NF1102	2620 x 1350	P220	stoc	LBA	26.43
LBA NF1102 2620x1370 P180	NF1102	2620 x 1370	P180	stoc	LBA	26.73
LBA NF1102 2620x1380 P120	NF1102	2620 x 1380	P120	stoc	LBA	26.73
LBA NF1102 2620x1380 P150	NF1102	2620 x 1380	P150	stoc	LBA	26.73







SESN – hartie E cu oxid de aluminiu dispus inchis + aditivi activi anti-static. Recomandat pentru slefuirea vopselelor pe bază de poliester, acrilice și poliacrilice. Alte dimensiuni și/sau granulatii se pot aduce pe comanda in cca 3 saptamani.

Cod Mentor	Cod Produs	 mm			Producator	 € +TVA
LBA SESN 2620x1350 P240	SESN	2620 x 1350	P240	stoc	LBA	23.74
LBA SESN 2620x1350 P320	SESN	2620 x 1350	P320	stoc	LBA	23.74
LBA SESN 2620x1350 P400	SESN	2620 x 1350	P400	stoc	LBA	23.74
LBA SESN 2620x1350 P600	SESN	2620 x 1350	P600	stoc	LBA	23.74
LBA SESN 2620x1370 P240	SESN	2620 x 1370	P240	stoc	LBA	24.05
LBA SESN 2620x1370 P320	SESN	2620 x 1370	P320	stoc	LBA	24.05
LBA SESN 2620x1370 P800	SESN	2620 x 1370	P800	stoc	LBA	24.05
LBA SESN 2620x1380 P320	SESN	2620 x 1380	P320	stoc	LBA	24.05
LBA SESN 2620x1380 P360	SESN	2620 x 1380	P360	stoc	LBA	24.05
LBA SESN 2620x1380 P400	SESN	2620 x 1380	P400	stoc	LBA	24.05
LBA SESN 2620x1380 P500	SESN	2620 x 1380	P500	stoc	LBA	24.05
LBA SESN 2620x1380 P500	SESN	2620 x 1380	P600	stoc	LBA	24.05
LBA SESN 2620x1380 P800	SESN	2620 x 1380	P800	stoc	LBA	24.05
LBA SESN 3250x1370 P400	SESN	3250 x 1370	P400	stoc	LBA	27.78
LBA SESN 3250x1370 P600	SESN	3250 x 1370	P600	stoc	LBA	27.78
LBA SESN 3250x1370 P800	SESN	3250 x 1370	P800	stoc	LBA	27.78

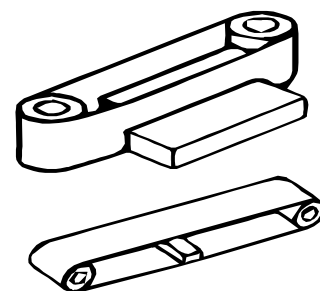











TXA – panza X din poli-bumbac cu oxid de aluminiu dispus deschis + aditivi activi anti-static. Recomandat pentru calibrarea/slefuirea elementelor din lemn masiv, furniruri. Alte dimensiuni si/sau granulatii se pot aduce pe comanda in cca 3 saptamani.

Cod Mentor	Cod Produs	 mm			Producator	 € +TVA
LBA TXA 6600x120 P80	TXA	6600 x 120	P80	stoc	LBA	10.83
LBA TXA 6600x120 P120	TXA	6600 x 120	P120	stoc	LBA	10.42

TLXGR – panza X din poli-bumbac cu oxid de aluminiu dispus semi-inchis + aditivi activi anti-static. Recomandat pentru calibrarea/slefuirea elementelor din lemn masiv, furniruri; metalelor neferoase, otel inoxidabil, aluminiu, alama etc.. Alte dimensiuni si/sau granulatii se pot aduce pe comanda in cca 3 saptamani.

Cod Mentor	Cod Produs	 mm			Producator	 € +TVA
LBA TLXGR 2000x150 P80	TLXGR	2000 x 150	P80	stoc	LBA	6.21
LBA TLXGR 2000x150 P120	TLXGR	2000 x 150	P120	stoc	LBA	6.21
LBA TLXGR 8010x120 P80	TLXGR	8010 x 120	P80	stoc	LBA	15.03
LBA TLXGR 8010x120 P100	TLXGR	8010 x 120	P100	stoc	LBA	15.03
LBA TLXGR 8010x120 P150	TLXGR	8010 x 120	P150	stoc	LBA	15.03

NF1102 – hartie F cu oxid de aluminiu dispus deschis. Recomandat pentru calibrarea/slefuirea elementelor din lemn masiv, furniruri, MDF, metale. Alte dimensiuni si/sau granulatii se pot aduce pe comanda in cca 3 saptamani.

Cod Mentor	Cod Produs	 mm			Producator	 € +TVA
LBA NF1102 4550x140 P180	NF1102	4550 x 140	P180	stoc	LBA	5.59
LBA NF1102 5520x150 P100	NF1102	5520 x 150	P100	stoc	LBA	6.37
LBA NF1102 5520x150 P120	NF1102	5520 x 150	P120	stoc	LBA	6.37



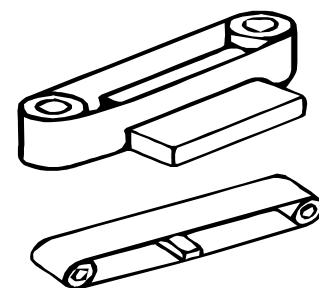

SESN – hartie E cu oxid de aluminiu dispus inchis + aditivi activi anti-static. Recomandat pentru slefuirea vopselelor pe bază de poliester, acrilice și poliacrilice. Alte dimensiuni și/sau granulatii se pot aduce pe comanda in cca 3 saptamani.

Cod Mentor	Cod Produs	mm			Producator	+TVA
LBA SESN 4550x140 P400	SESN	4550 x 140	P80	stoc	LBA	5.08
LBA SESN 5100x120 P320	SESN	5100 x 120	P320	stoc	LBA	4.92
LBA SESN 5100x120 P500	SESN	5100 x 120	P500	stoc	LBA	4.92
LBA SESN 5100x120 P800	SESN	5100 x 120	P800	stoc	LBA	4.92
LBA SESN 5450x120 P320	SESN	5450 x 120	P320	stoc	LBA	5.15
LBA SESN 5450x120 P400	SESN	5450 x 120	P400	stoc	LBA	5.15
LBA SESN 5520x150 P240	SESN	5520 x 150	P240	stoc	LBA	5.73
LBA SES 7350x150 P400	SESN	7350 x 150	P400	stoc	LBA	6.99
LBA SES 7350x150 P500	SESN	7350 x 150	P500	stoc	LBA	6.99
LBA SES 7350x150 P600	SESN	7350 x 150	P600	stoc	LBA	6.99
LBA SES 7350x150 P800	SESN	7350 x 150	P800	stoc	LBA	6.99

TLJ – panza J flexibila cu oxid de aluminiu dispus semi-deschis + aditivi activi anti-static. Recomandat pentru slefuirea elementelor din lemn masiv, furniruri; metalelor neferoase, otel inoxidabil, aluminiu, alama etc.. Alte dimensiuni și/sau granulatii se pot aduce pe comanda in cca 3 saptamani.

Cod Mentor	Cod Produs	mm			Producator	+TVA
LBA TLJ 2250x100 P180	TLJ	2250 x 100	P180	stoc	LBA	3.65
LBA TLJ 2250x100 P320	TLJ	2250 x 100	P320	stoc	LBA	3.65
LBA TLJ 2752x60 P80	TLJ	2752 x 60	P80	stoc	LBA	2.53
LBA TLJ 2752x60 P120	TLJ	2752 x 60	P120	stoc	LBA	2.48
LBA TLJ 2752x60 P180	TLJ	2752 x 60	P180	stoc	LBA	2.48

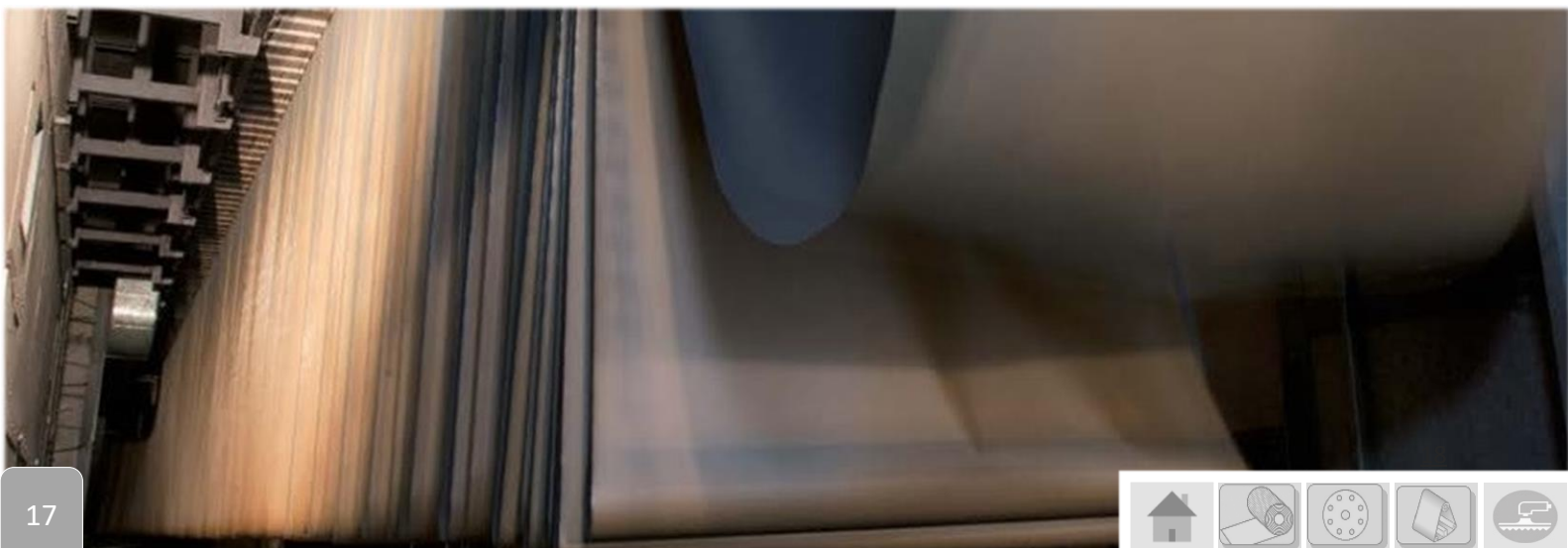

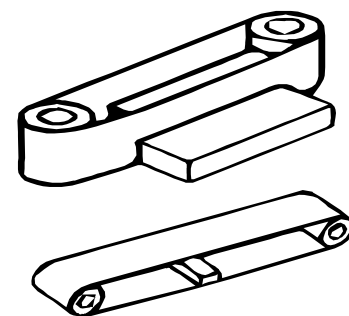

TLJ – panza flexibila J cu oxid de aluminiu dispus semi-deschis + aditivi activi anti-static. Recomandat pentru slefuirea elementelor din lemn masiv, furniruri; metalelor neferoase, otel inoxidabil, aluminiu, alama etc.. Alte dimensiuni si/sau granulatii se pot aduce pe comanda in cca 3 saptamani.

Cod Mentor	Cod Produs	mm			Producator	+TVA
LBA TLJ 2780x80 P80	TLJ	2780 x 80	P80	stoc	LBA	3.80
LBA TLJ 2780x80 P100	TLJ	2780 x 80	P100	stoc	LBA	3.74
LBA TLJ 2780x80 P120	TLJ	2780 x 80	P120	stoc	LBA	3.74
LBA TLJ 2780x80 P150	TLJ	2780 x 80	P150	stoc	LBA	3.74
LBA TLJ 2780x80 P180	TLJ	2780 x 80	P180	stoc	LBA	3.74
LBA TLJ 2780x80 P240	TLJ	2780 x 80	P240	stoc	LBA	3.74
LBA TLJ 2800x60 P320	TLJ	2800 x 60	P320	stoc	LBA	3.74
LBA TLJ 2800x60 P400	TLJ	2800 x 60	P400	stoc	LBA	3.74
LBA TLJ 2800x70 P120	TLJ	2800 x 70	P120	stoc	LBA	3.13
LBA TLJ 2800x70 P150	TLJ	2800 x 70	P150	stoc	LBA	3.13
LBA TLJ 2800x70 P240	TLJ	2800 x 70	P240	stoc	LBA	3.13
LBA TLJ 2800x70 P280	TLJ	2800 x 70	P280	stoc	LBA	3.13
LBA TLJ 2800x70 P400	TLJ	2800 x 70	P400	stoc	LBA	3.13

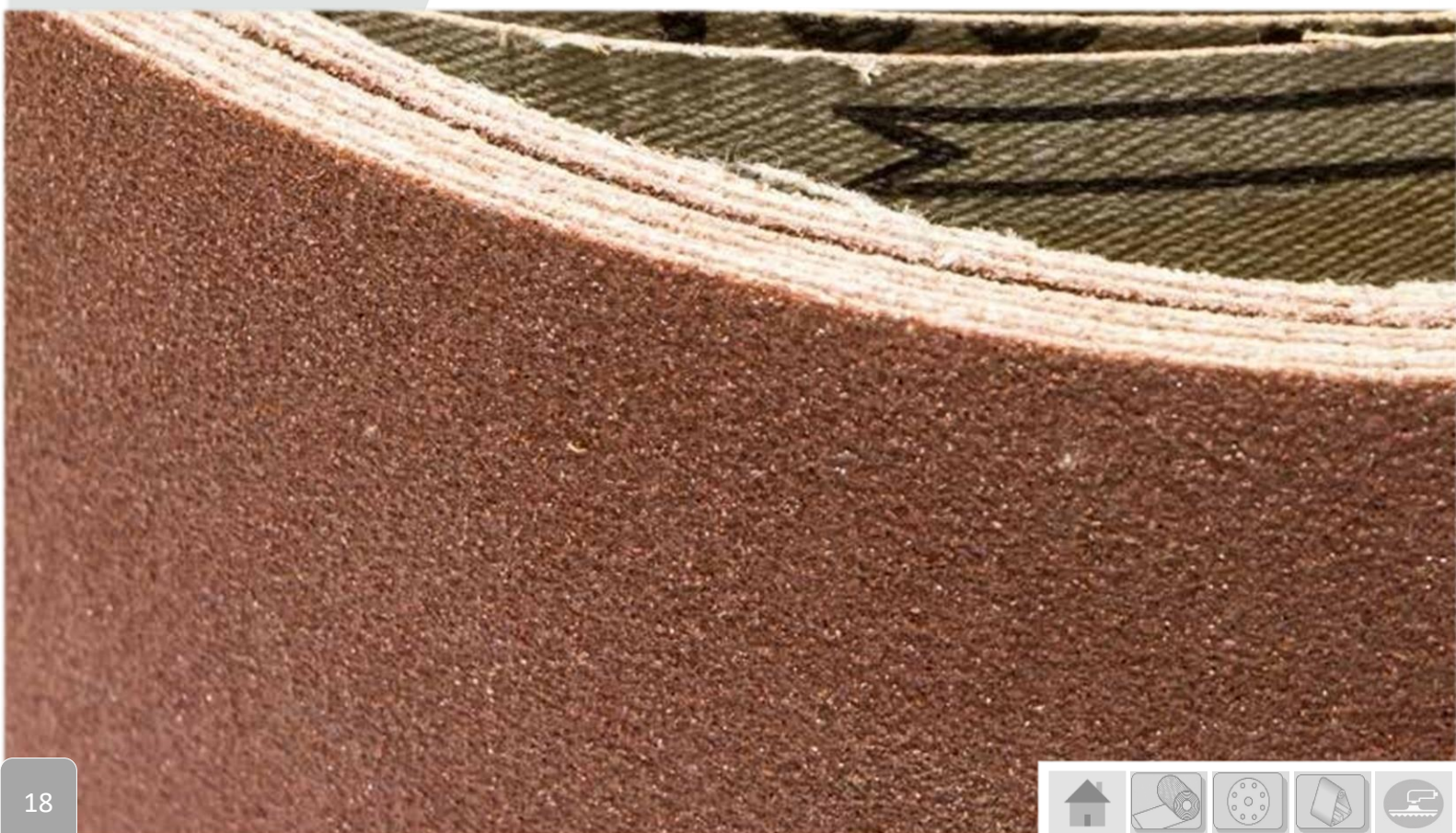

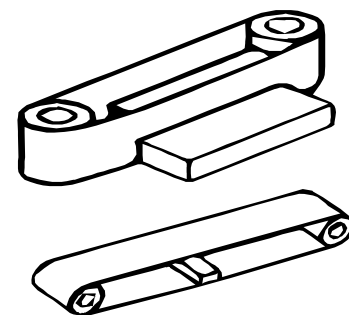

TLJ – panza flexibila J cu oxid de aluminiu dispus semi-deschis + aditivi activi anti-static. Recomandat pentru slefuirea elementelor din lemn masiv, furniruri; metalelor neferoase, otel inoxidabil, aluminiu, alama etc.. Alte dimensiuni si/sau granulatii se pot aduce pe comanda in cca 3 saptamani.

Cod Mentor	Cod Produs	mm			Producator	+TVA
LBA TLJ 3000x70 P180	TLJ	3000 x 70	P180	stoc	LBA	3.28
LBA TLF 3000x60 P320	TLJ - TLF	3000 x 60	P320	stoc	LBA	2.62
LBA TLF 3000x60 P400	TLJ - TLF	3000 x 60	P400	stoc	LBA	2.62
LBA TLF 3000x70 P320	TLJ - TLF	3000 x70	P320	stoc	LBA	3.28
LBA TLF 3000x70 P400	TLJ - TLF	3000 x70	P400	stoc	LBA	3.28
LBA TLJ 3000x90 P180	TLJ	3000 x 90	P180	stoc	LBA	3.92
LBA TLJ 4800x150 P280	TLJ	4800 x 150	P280	stoc	LBA	9.09
LBA TLJ 5100x120 P120	TLJ	5100 x 120	P120	stoc	LBA	7.62
LBA TLJ 5100x120 P150	TLJ	5100 x 120	P150	stoc	LBA	7.62
LBA TLJ 7100x120 P80	TLJ	7100 x 120	P80	stoc	LBA	10.11
LBA TLJ 7100x120 P120	TLJ	7100 x 120	P120	stoc	LBA	9.89
LBA TLJ 7100x120 P100	TLJ	7100 x 120	P100	stoc	LBA	9.89





SAITmaster



SAITMASTER 3 - Rotororbitala pneumatica cu system de aspiratie central. Recomandata pentru operatii de slefuire cu granulatii cuprinse intre P320 - P3000. Excentricul mic asigura rezultate de inalta calitate, facand usoara si imbunatatind urmatoarea faza de vopsire. Presiunea de lucru: 6,2 bar/90 psi.

Cod Mentor	Cod Produs	mm	RPM		Producator	€ +TVA
AB SAITMASTER 3	SAITMASTER 3 150x3 PN	3	0 - 11000	stoc	Sait	300
NAB INTER10MM15F	INTERFATA 10mm Ø150 15F	---	---	stoc	Sait	6.44
NAB INTER5MM15F	INTERFATA 5mm Ø150 15F	---	---	stoc	Sait	6.44
NAB PLAT150QMW	PAD Ø150 15H MEDIUM	---	max. 10000	stoc	Napoleon	22.09
NAB PLAT75QMW	PAD Ø150 75H MEDIUM	---	max. 10000	stoc	Napoleon	22.09

VORTEX L

VORTEX L 2400 AS - Aspirator profesional la care pot fi conectate doua ustensile pneumatice sau o ustensila electrica (max. 2400W). Este doatt cu: 1 furtun de aspiratie de 5 ml | 1 conector frontal | 1 furtun de aer comprimat cu regulator de aer | 1 conector cu 2 cai | 2 filtre din polyester | 1 sac de colectarea prafului



Cod Mentor	Cod Produs	cm	Volum sac		Producator	€ +TVA
AB VORTEX L 2400 AS	VORTEX L 2400 AS	63,5 x 45 x 45	45 litri	stoc	Sait	687.07
AB PACHET SLEFUIRE FARA PRAF		Roto-orbitala + aspirator		stoc	----	838
	Filtru poliesteric	----	----	3 - 4 saptamani	Sait	32.51
	Sac	----	----	3 - 4 saptamani	Sait	10.09



Posibilitatea de conectare a 2 scule pneumatice sau una electrica

Lumina albastra indica faptul ca aspiratorul este gata de folosire. Selector al modului de lucru: manual - automat. Variator de putere al motorului 350W - 1200W.



Ledul rosu: service | Ledul galben: sacul este plin | Ledul verde: motorul functioneaza

In partea posterioara a aspiratorului este un buzunar pentru depozitarea furtunului si a cablului de alimentare.



Pe partea superioara a aspiratorului se afla un raft multifunctional unde se pot depozita sculele si accesoriile.



X-SPACE



X-SPACE 21 180 EL S – Masina de polish-at cu o miscare orbitala mare pentru reducerea timpilor de lucru. Excentric de pana la 21 mm pentru obtinerea rapida a luciului si a profunzimi. Variator de turatie electronic | Soft Start pentru controlul turatiei si imprastierea pastei de polish | Maner frontal ergonomic | Motor de 500W | Potrivita pentru toate operatiile de polish-are si pe toate tipurile de suprafata, inclusive pentru inlaturarea hologramelor.

Cod Mentor	Cod Prods	mm			Producator	€ +TVA
AB X-SPACE21 180ELS	X-SPACE 21	21	2000 - 4200	stoc	Sait	369

ALBASTRU – Burete rigid, dur, din spuma pentru îndepărtarea defectelor medii – severe. Se folosește împreună cu: PASL10 BN; PASL20 VR



Cod Mentor	Cod Prods	mm			Producator	€ +TVA
AB PAD 180x30 BLU	CORSE	Ø180 x 30	Rigid	stoc	Sait	11.17

GALBEN – Burete din spuma fina, pentru inlaturarea defectelor medi-fine si a da luci. Se foloseste impreuna cu: PASL20 VR; PASL30 GB



Cod Mentor	Cod Prods	mm			Producator	€ +TVA
AB PAD 180x30 GIALLO	FINE	Ø180 x 30	Intermediar	stoc	Sait	11.17

ALB – Burete din spuma moale, pentru inlaturarea defectelor fine si de a da luci. Se foloseste impreuna cu: PASL30 GB; PASL40 RO



Cod Mentor	Cod Prods	mm			Producator	€ +TVA
AB PAD 180x30 BIANCO	ULTRA FINE	Ø180 x 30	Moale	stoc	Sait	11.17





PASL10 BN – Pasta abraziva agresiva, granulatie mediu-grosiera. Recomandata pentru reimprospatarea vopselelor imbatranite sau foarte zgariate si pentru suprafete slefuite cu granulatii cuprinse intre P1200 – P2000 impreuna cu buretele **AB PAD 180x30 BLU**.



Cod Mentor	Cod Produs	Abraziune	Brillantete		Producator	€ +TVA
AB PASL10BN-005	PASL10 BN	10/10	4/10	stoc	Sait	12.62

PASL20 VR - Pasta abraziva all-in-one, granulatie mediu-fina. Recomandata pentru reimprospatarea vopselelor imbatranite sau usor zgariate si pentru suprafete slefuite cu granulatii cuprinse intre P1500 – P3000 si/sau dupa **PASL10 BN** impreuna cu buretele **AB PAD 180x30 GIALLO**.



Cod Mentor	Cod Produs	Abraziune	Brillantete		Producator	€ +TVA
AB PASL20VR-005	PASL20 VR	8/10	9/10	stoc	Sait	16.20

PASL30 GB - Pasta abraziva anti-holograma, granulatie extra-fina. Recomandata pentru eliminarea de holograme pe culorile inchise sau defecte generate de pastele precedente impreuna cu buretele **AB PAD 180x30 GIALLO**.



Cod Mentor	Cod Produs	Abraziune	Brillantete		Producator	€ +TVA
AB PASL30GB-005	PASL30 GB	10/10	7/10	stoc	Sait	15.34

PASL40 RO - Pasta protective. Pentru operatii manuale sau cu masina pentru a conferii brilantenta impreuna cu buretele **AB PAD 180x30 BIANCO**.



Cod Mentor	Cod Produs	Abraziune	Brillantete		Producator	€ +TVA
AB PASL40RO	PASL40 RO	10/10	-----	stoc	Sait	11.06

PASL60 SC – Spray detergent. Utilizat pentru indepartat si decontaminat suprafetele proaspat polish-ate.



Cod Mentor	Cod Produs	Abraziune	Brillantete		Producator	€ +TVA
AB PASL60SC	PASL60 SC	----	-----	stoc	Sait	11.36



Gramă de abrazive comercializată de *Aquatec Evolution* este vastă și cuprinde abrazive pentru: *slefuire manuală*: role panza, role hartie etc; *slefuire semi-automată*: discuri, benzi continue pentru slaif; *slefuire automată*: benzi continue; și sunt în conformitate cu standardele impuse de *FEPA*.



Produsele abrazive trebuie depozitate la temperaturi ambientale de circa 20°C și umiditate relativă de 65%, departe de surse de căldură și suprafețe umede.

Suporturi din panza abraziva:

- ❖ H – panza poliesterică foarte densă, rigidă și rezistentă. Pentru operații de degrosare și calibrare. Rezistența la apă.
- ❖ X – panza din bumbac sau poli-bumbac densă și rezistentă. Pentru operații de calibrare, slefuire.
- ❖ J – panza din bumbac flexibil. Pentru operații de slefuire și slefuire între straturi.
- ❖ F – panza din bumbac foarte flexibilă și moale. Pentru operații de slefuire și slefuire între straturi a pieselor curbate.

Suporturi din hartie abraziva:

- ❖ B – hartie subțire de 90 – 115 gr/m². Pentru operații manuale și cu mașinute orbitale
- ❖ C – hartie subțire de 115 – 130 gr/m². Pentru operații manuale și cu mașinute orbitale
- ❖ D – hartie medie de 150 – 200 gr/m². Pentru operații cu mașinute orbitale
- ❖ E – hartie groasă de 225 – 250 gr/m². Pentru operații mecanice, slaifuri sau grupuri transversale
- ❖ F – hartie groasă de 250 – 300 gr/m². Pentru operații mecanice, slaifuri sau grupuri transversale
- ❖ G – hartie foarte groasă de 400 – 450 gr/m². Pentru operații mecanice, slaifuri sau grupuri transversal

Alte suporturi abrazive:

- ❖ TNT – panza netesută tridimensională abrazivă

Produsele abrazive comercializate de *Aquatec Evolution* sunt fabricate și strict controlate pentru a garanta siguranța operatorilor în condiții corecte de utilizare.

Mășinile utilizator trebuie să fie de putere și viteză adecvate, în condiții bune de eficiență și echipate cu mijloace de protecție adecvate.

Asamblarea atentă este esențială pentru siguranța și performanța produselor abrazive. Viteza de utilizare nu trebuie să depășească viteza maximă admisă pentru produse individuale.

Este esențial ca operatorii să fie protejați individual și corespunzător cu ochelari, manși și sorturi împotriva oricărui proiectii de materiale, precum și cu masti de praf și casti pentru urechi. Utilizarea acestor utilaje poate provoca zgomot egal sau mai mare de 85 dBA, prin urmare operatorul trebuie să fie protejat cu casti sau alte protecții individuale adecvate.

Nerespectarea acestei reguli poate duce la riscul afectării funcțiilor auditive.



Respectați măsurile de protecția muncii



Purtați mască de protecție



Purtați protecție auditivă



Purtați manși de protecție



Purtați ochelari de protecție



- 0314.347.666

Bd. Theodor Pallady nr. 66D-E, Sector 3, Bucuresti, 032266

Str. Gib Mihaescu 14, Ramnicu Valcea, Valcea, 240141

Calea Chisinaului 43A, Iasi, 700179

www.aquatecevolution.ro | comercial@aquatecevolution.ro

Follow us on ↓

Facebook – YouTube – LinkedIn – Instagram
